

20

PRODUCT NAME
Two Hole Mixer
 INTERNAL FIRST FIX: W2HMIXIP

Studio/ORE

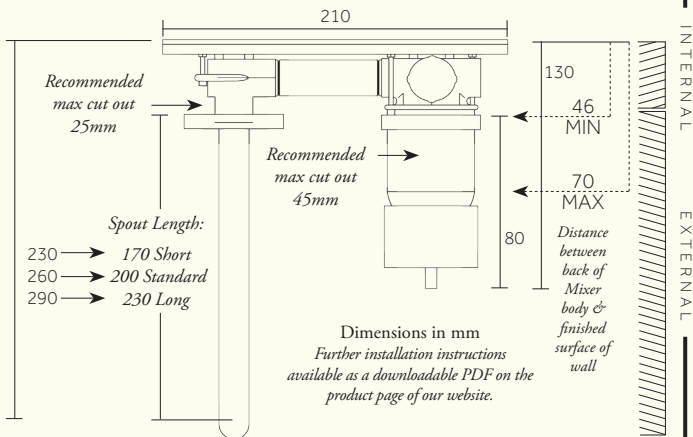
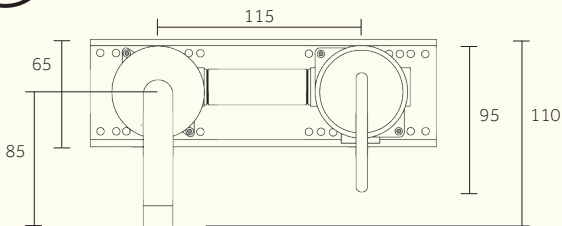

Min/Max Operating pressure: (bars)	2.0 - 5.0					
Flow rates: Bar/L per min (with Aerator)	0.5/4.9	1/6.5	2/8.4	3/8.2	4/7.8	5/7.8
Flow rates: Bar/L per min (without Aerator)	0.5/10.3	1/14.2	2/19.8	3/24.1	4/27.9	5/31
Connection:	1/2" BSP (NPT ADAPTERS ARE AVAILABLE)					
Flow Restrictor:	PCA TJ 8.0 LTR					

*Available with 'Back Plate', 201 for fixing to wall.
 **Handle also available as a Steam Wheel or Lever. Not shown in diagram.