

201

PRODUCT NAME

Studio/ORE

Two Hole Mixer (with Back Plate)

INTERNAL FIRST FIX: W2HMIXIP-V1

Back Plate*
w 215 x d 100

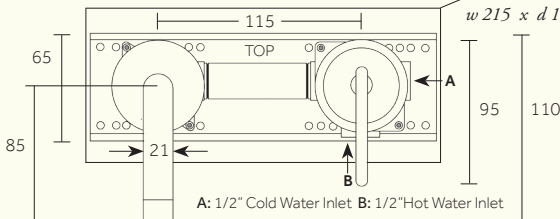

A: 1/2" Cold Water Inlet B: 1/2" Hot Water Inlet

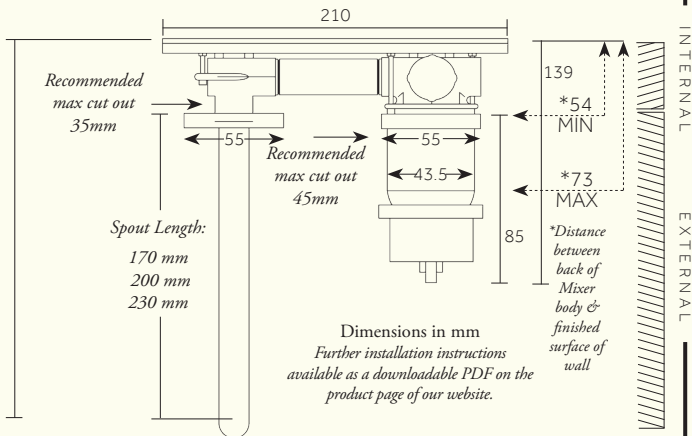

Spout Length:

170 mm
200 mm
230 mm

Dimensions in mm
Further installation instructions
available as a downloadable PDF on the
product page of our website.

Min/Max Operating pressure: (bars)	2.0 - 5.0					
Flow rates: Bar/L per min (with Aerator)	0.5/4.9	1/6.5	2/8.4	3/8.2	4/7.8	5/7.8
Flow rates: Bar/L per min (without Aerator)	0.5/10.3	1/14.2	2/19.8	3/24.1	4/27.9	5/31
Connection:	1/2" BSP (NPT ADAPTERS ARE INCLUDED)					
Flow Restrictor:	5.0 - 8.0 LTR PCA (8L per min)					

*Back Plate fixes to front of wall. Handle is also available as a Steam Wheel or Lever. Not shown in diagram.