

Shower Thermostat and Triple Shower Thermostat

Product shown will vary depending on model

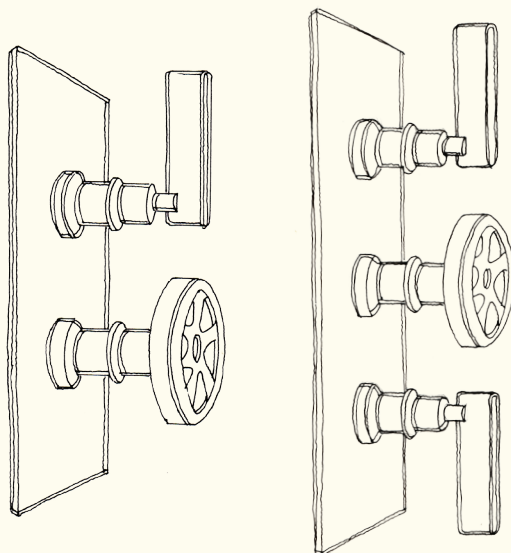

Important information:

To ensure this product is installed properly you must read and follow these guidelines.

The owner/user of this product must keep this information for future reference.

This product must be installed by a professional licensed contractor.

Only use a strap wrench or protected smooth jaw on any finished surface.

ORE

Contents:

1. *Important Information* (p1)
2. *Cleaning and Aftercare* (p2)
 3. *Box Contents* (p2)
 4. *Technical Data* (p2)
 5. *Dimensions* (p3-5)
 6. *Installation* (p6 - 8)
7. *Temperature Adjustment* (p9 - 10)
8. *Conditions of Use* (p11 - 13)
9. *Fault Diagnosis* (p13)

1 Important information

- This installation guide is for the Twin and Triple Concealed Thermostatic Shower Valve. It covers the installation, maintenance and operation of the Shower Valve. To ensure you get the very best use from this product, please read this installation guide thoroughly.
- The Twin and Triple Concealed Valve is thermostatically regulated by a wax element. It is designed to provide a flow of water at a safe temperature when installed as described in this manual. The valve is suitable for both low and high pressure installations. The valve is suitable, without modification, for all types of installation, including pumped gravity systems, mains pressure and combination boilers.
- Please make sure that any auxilliary systems (e.g. shower kits) are suitable for connection to this product.
- Debris in the new pipe work can get in to the Cartridges. This is easily avoided by thoroughly flushing the pipe work **before** connecting the Shower Valve to the water supplies.
- This product must be installed in such a way as not to cause water damage during use. We recommend that this product is fitted by a fully qualified installer. ***The installation must comply with all current water byelaws.***

NB. If you experience any difficulty with the installation or operation of your new Shower Valve, please refer to 'Fault Diagnosis' at the end of this guide.

2 Cleaning and Aftercare

- This product is made of Brass and is available in a variety of finishes, if you need further information on cleaning and maintenance please see our full instructions. These can be found on our website or on the care slip provided in the box with your product. All finishes should only be cleaned with non-abrasive products or materials and a soft cloth, and ***any misuse will invalidate your guarantee.***

- This precision-made Thermostatic Shower Valve will continue to give years of use provided it has been installed and operated in accordance with these fitting instructions. *Failure to do this will invalidate any guarantees.*

3 Box Contents

Please note: Handles and Plate may vary depending on model supplied.

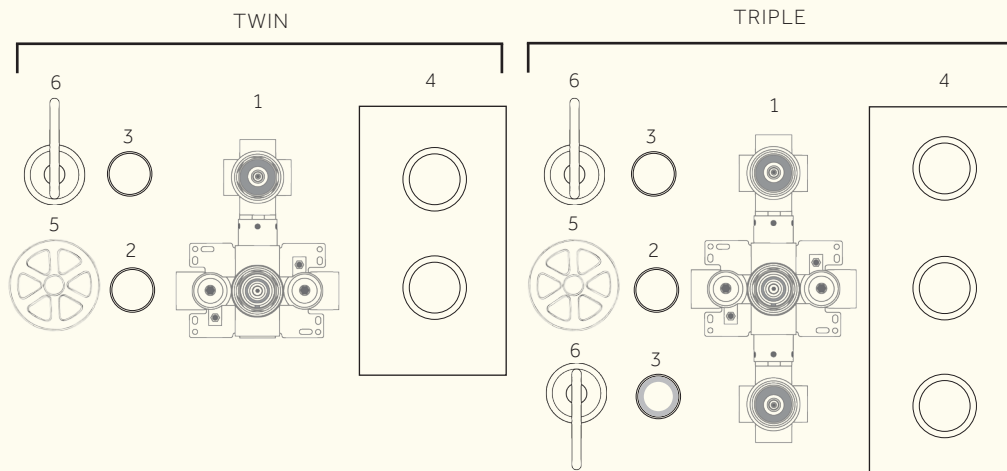

1 Main Thermostatic Shower Valve Body. **2** Brass Temperature Body Sleeve. **3** Brass Control Sleeve. **4** Brass Concealing Plate. **5** Brass Thermostatic Control Handle. **6** Brass Flow Control Handle.

4 Technical Data

Max Dynamic Pressure: 5 bar

Min Dynamic Pressure: 0.2 bar

Factory Outlet Temperature Setting: 43°C

Minimum Temperature Differential (mixed water to hot water): 10°C

Temperature Stability: +/- 2°C

The valve is suitable, without modification, for all types of installation, including pumped gravity systems, mains pressure and combination boilers.

5 Dimensions

ALL DIMENSIONS ARE APPROXIMATE (MM)

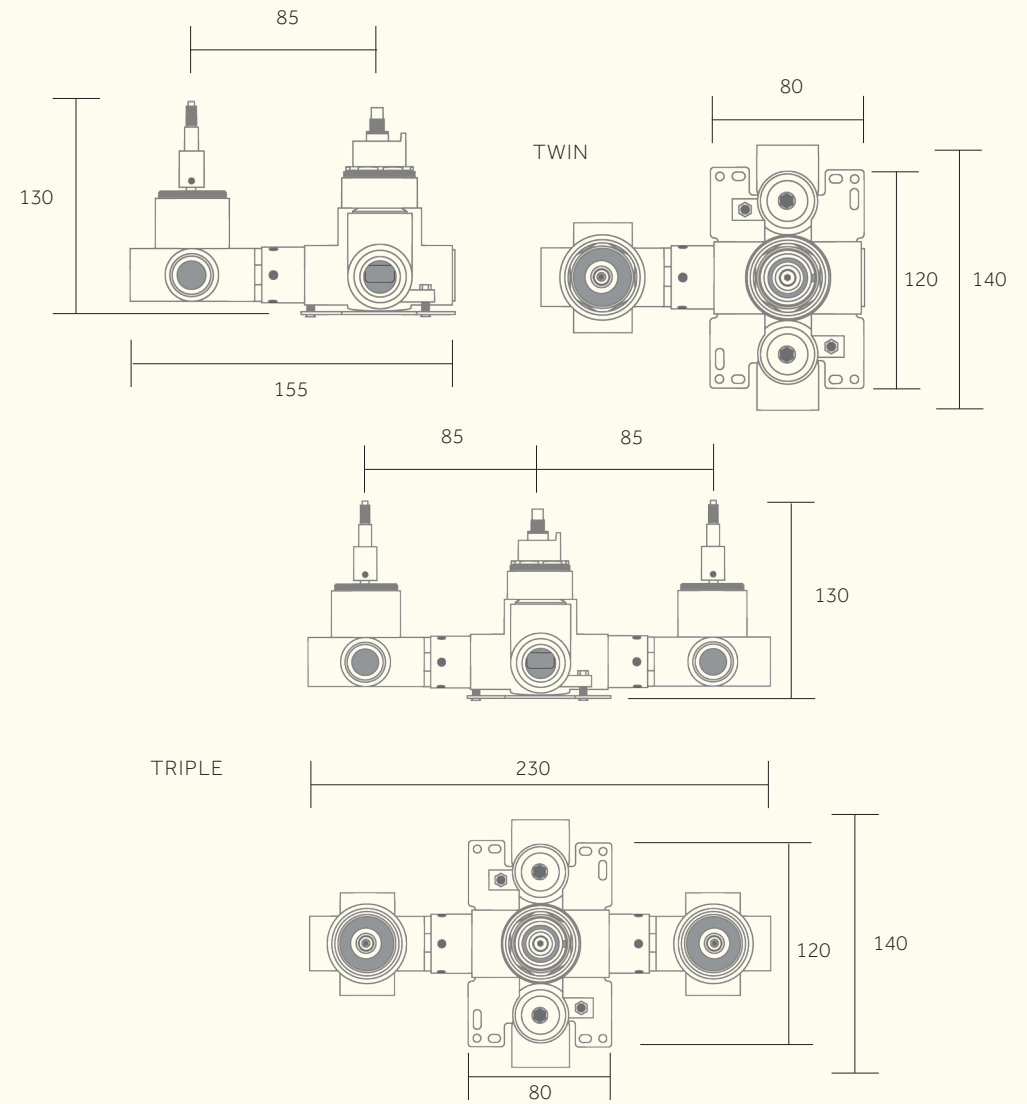

Dimensions including external components

ALL DIMENSIONS ARE APPROXIMATE (mm)

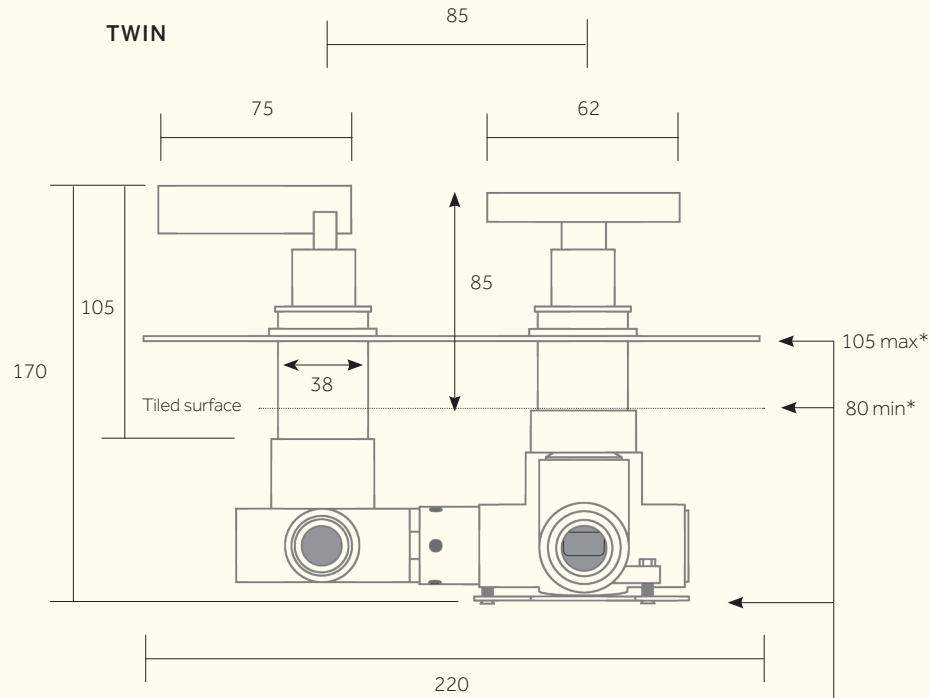

*Distance between back of fixing plate and finished surface of wall

Min/Max Operating pressure: (bars)	1.0 - 5.0				
Flow rates: Bar/L per min	1.0/10.2	2.0/14.2	3.0/17.4	4.0/20.1	5.0/22.5
Connection:	3/4" BSP (NPT ADAPTERS ARE AVAILABLE)				

4

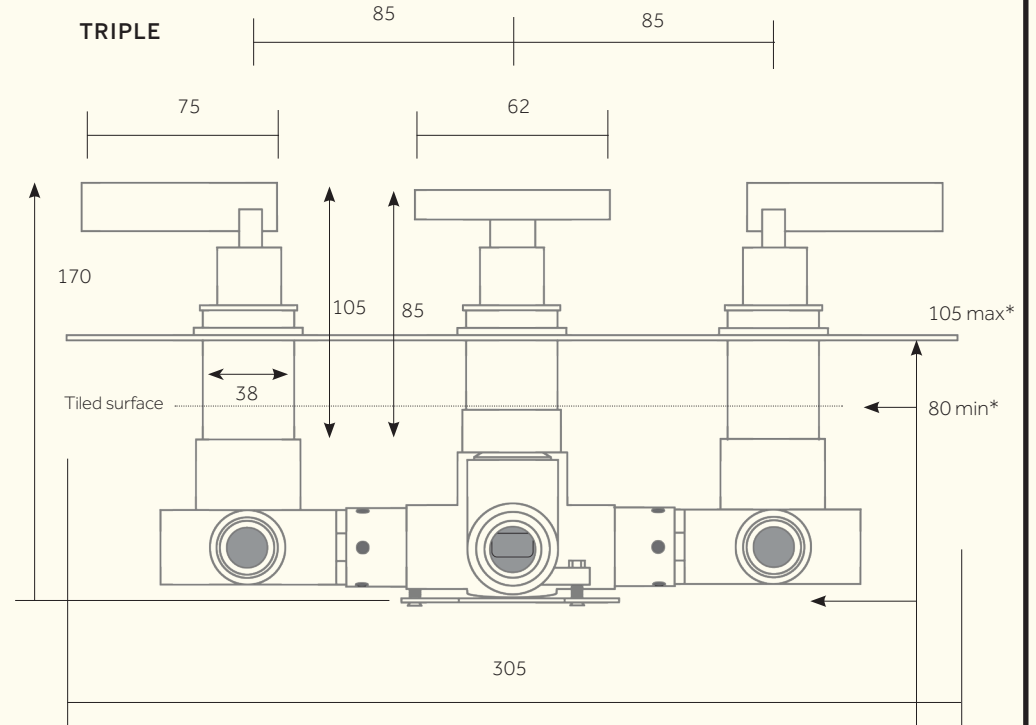

*Distance between back of fixing plate and finished surface of wall

Min/Max Operating pressure: (bars)	1.0 - 5.0				
Flow rates: Bar/L per min (ON/OFF: 1 CLOSED, 1 OPEN)	1.0/10.0	2.0/14.1	3.0/17.2	4.0/19.9	5.0/22.2
Flow rates: Bar/L per min (ON/OFF: BOTH OPEN)	1.0/10.7	2.0/14.9	3.0/18.3	4.0/21.1	5.0/23.6
Connection:	3/4" BSP (NPT ADAPTERS ARE AVAILABLE)				

5

6 Installation

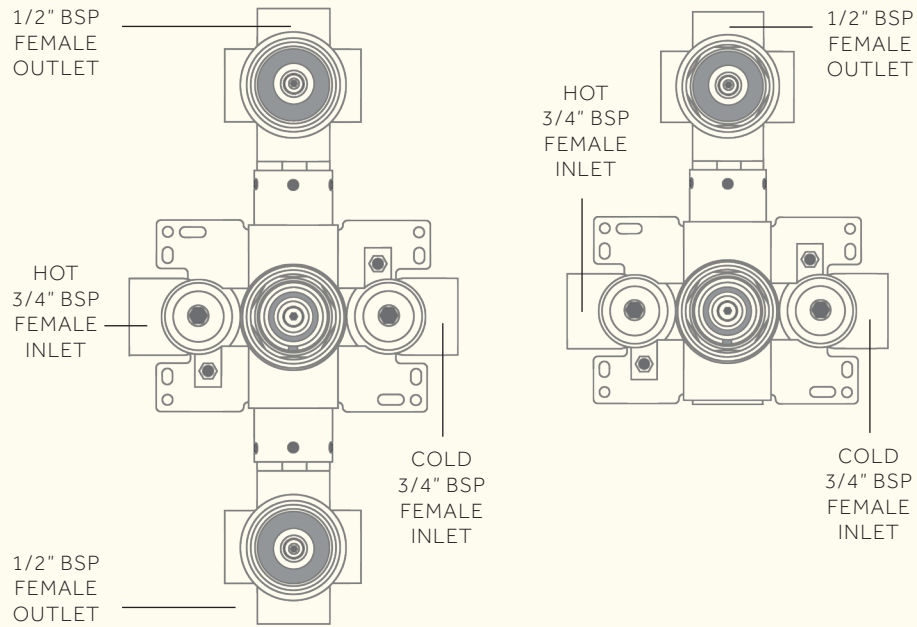

Twin Valve: The hot inlet of the valve must be connected to the hot pipe work. The hot inlet of the valve will be marked. When installed correctly the outlet will be facing up.

Triple Valve: The hot inlet of the valve must be connected to the hot pipe work. The hot inlet of the valve will be marked.

PLEASE NOTE: *The pipe work on-site should be plumbed with the hot on the left and the cold on the right as you look at it.*

1. Before installation, please read the Conditions of Use and ensure the system supply conditions comply.
2. Remove the Brass sleeves from the Shower Valve body, and leave to one side in a safe place.
3. You must install accessible isolation valves in the HOT and COLD water supply lines for servicing purposes.
4. The plumbing connections on the inlets and outlet are all 1/2" BSP female threads.
5. Determine the fixing position for the valve and make a recess in the wall to house the valve. It should be from 68 to 90mm deep depending on how far you wish the valve to protrude.
6. Screw the Shower Valve body in position, using the mounting lugs that are cast into the base of the body.

7. Now the Shower Valve body is securely mounted onto the wall, make sure the pipe work is thoroughly flushed through to remove any debris from the system before connecting the water supplies. ***Failure to do this could invalidate the guarantee.***
8. The plumbing connections should then be made to the HOT and COLD water inlets (which are clearly marked). ***If for some reason the pipe work feeds on site are the wrong way around, the Cartridge can be taken out of the valve body, turned 180° and placed back in the valve body.***
9. Make the plumbing connection to the water outlet. This will take the water to the chosen auxilliary product (shower kit) you have selected to install.
10. Turn on the water supply and check for leaks.
11. Check the max water temperature from the terminal fitting with a thermometer. The recommended max terminal outlet temperature is 41°C. If the water temperature is not suitable please see the Temperature Adjustment Section. ***Please note: The mixed water temperature at the terminal fitting must never exceed 46°C.***
12. Re fit the Brass sleeves to the Shower body.
13. Apply a small bead of silicone behind the brass concealing plate (this will give a water-tight seal so that water cannot ingress into the wall cavity). Slide the plate into position over the Brass sleeves, and fit up against the finished wall surface. We recommend applying a small amount of silicone grease to the O-Rings on the Shower plate. This will allow it to slide onto the cylinders with ease.
14. Fit the Brass Control Handles. The Flow Control Handle is always a lever, unless the purchaser has chosen otherwise. Please see separate installation and alignment guide.
15. Please see the Conditions of Use section.

7 Temperature Adjustment

1. Remove the Handle on the Thermostat Control. This can be loosened by undoing the concealed grub screw with the allen key supplied. Unscrew the Brass sleeve. The Brass Stop Lug will now be exposed.
2. Turn the Shower Flow Control fully on.
3. If the shower is too cold then turn the Spline anti-clockwise. If the Shower is too hot then turn the Spline clockwise. Let the water temperature stabilise after every adjustment. We recommend a max temperature of 41°C.
The mixed water temperature at the terminal fitting must never exceed 46°C.
4. When the temperature is correct turn the Flow Control off. Do not move the Spline again until after the Handle is secured in place. The maximum temperature is now set and any movement of the Spline will alter the temperature.
5. The Handle can now be put back in place. ***When the Handle is being placed over the Spline, please ensure that the Handle Stop Lug is against the Cartridge Stop Lug preventing the handle from being turned any further anti-clockwise. This prevents the Shower Valve from reaching a temperature that is higher than the set point.***
Depending on your Handle type, the temperature will be limited by a Handle with an in-built Stop Lug or by a separate Cartridge Stop Lug. Please see the diagrams on the next page.
6. The Handle can now be fixed in place. The Shower should have a safe maximum showering temperature.

CARTRIDGE STOP LUG

The Handle Stop Lug should be against this face at the maximum temperature setting. This stops further anti-clockwise movement.

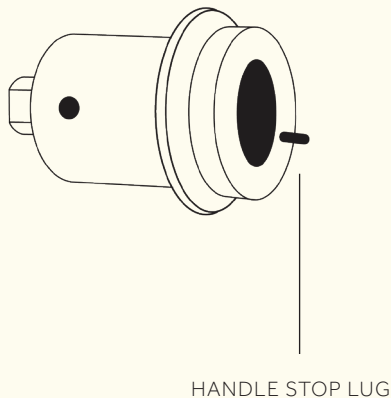
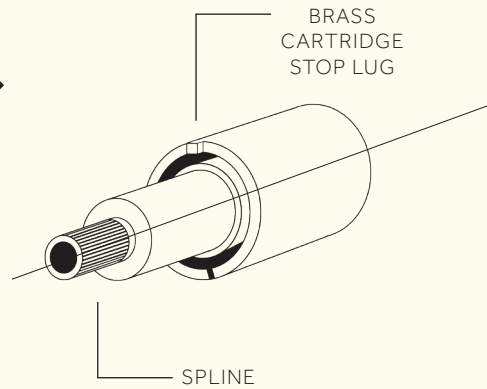

8 Conditions of Use

	<i>High Pressure</i>	<i>Low Pressure</i>
Maximum Static Pressure - Bar	10	10
Flow Pressure, Hot & Cold - Bar	0.5 to 5	0.1 to 1
Hot Supply Temperature - °C	55 to 65	55 to 65
Cold Supply Temperature - °C	Equal to or less than 25°	Equal to or less than 25°

Note: Valves operating outside these conditions cannot be guaranteed to operate thermostatically.

Designation of Use:

High Pressure Shower and Low Pressure Shower.

Recommended Outlet Temperatures:

44° for bath fill but see notes below;

41° for showers;

41° for wash basins;

38° for bidets.

The mixed water temperature must never exceed 46°C. The maximum mixed water temperature can be 2°C above the recommended maximum set outlet temperatures.

PLEASE NOTE: 46°C is the maximum mixed water temperature from the bath tap. The maximum temperature takes account of the allowable temperature.

tolerances inherent in Thermostatic Mixing Valves and temperature losses in metal baths. It is not a safe bathing temperature for adults or children. The British Burns Association recommends 37°C to 37.5°C as a comfortable bathing temperature for children. In premises covered by the Care Standard Act 2000, the maximum mixed water outlet temperature is 43°C.

The Thermostatic Mixing Valve will be installed in such a position that maintenance of the TMV and its valves and the commissioning and testing of the TMV can be undertaken. The fitting of isolation valves is required as close as possible to the water supply inlets of the Thermostatic Mixing Valve.

Commissioning notes for Thermostatic Mixing Valves.

The designation of the Thermostatic Mixing Valve is to check the following:

1. The designation of the Thermostatic Mixing Valve matches the application.
2. The supply pressures are within the valves operating range.
3. The supply temperatures are within the valves operating range.
4. Isolating valves (and strainers preferred) are provided.

If all the conditions are met, proceed to set the temperature as stipulated in the manufacturer's installation instructions.

It is recommended that valves should be tested against the original set temperature results once a year. When testing, the following performance checks should be carried out:

Measure the mixed water temperature at the outlet.

Carry out the cold water supply isolation test by isolating the cold water supply to the TMV, wait for 5 seconds if water is still flowing, check that the temperature is below 46°C. If there is no significant change to the set outlet temperature (+/- 2°C or less change from the original settings) and the fail-safe shut off is functioning, then the valve is working correctly and no further service work is required.

PLEASE NOTE: If there is a residual flow during the commissioning or the annual verification (cold water supply isolation test), then this is acceptable providing the temperature of the water seeping from the valve is no more than 2°C above the designated maximum mixed water outlet temperature setting of the valve.

Temperature readings should be taken at the normal flow rate after allowing for the system to stabilise. The sensing part of the thermometer should be fully submerged in the water that is to be tested.

9 Fault Diagnosis

<i>FAULT</i>	<i>POSSIBLE CAUSE</i>
<i>After installation, shower only runs HOT or COLD.</i>	1. Hot and cold water supplies are plumbed to the wrong sides of the valves.
<i>Shower will not run hot enough when first installed.</i>	1. Check hot water supply temperature. 2. Maximum temperature needs adjusting. See Temperature Adjustment Section. 3. Operating conditions are incorrect. 4. Blockage in hot side of the system.
<i>Hot water in cold and vice versa.</i>	1. Check and clean the check valves, as they may be obstructed.
<i>Low, or no flow from the valve.</i>	1. Possible blockage in the system. 2. Operating conditions are incorrect. 3. Valve being obstructed by debris. 4. Valve shut off has activated due to Operating Conditions.
<i>Leak from valve in the off position.</i>	1. Debris has gotten into the Diverter Valve.
<i>Fluctuating flow rate.</i>	1. Possible blockage in the system. 2. Operating Conditions are incorrect. 3. Dynamic inlet pressures are not balanced. 4. Shuttle assembly is faulty.

INSTALLER DETAILS:

ORE